

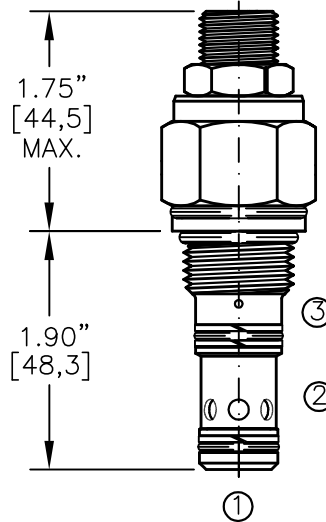

# COUNTERBALANCE VALVE POPPET TYPE, WITH FREE REVERSE FLOW & VENTED PISTON

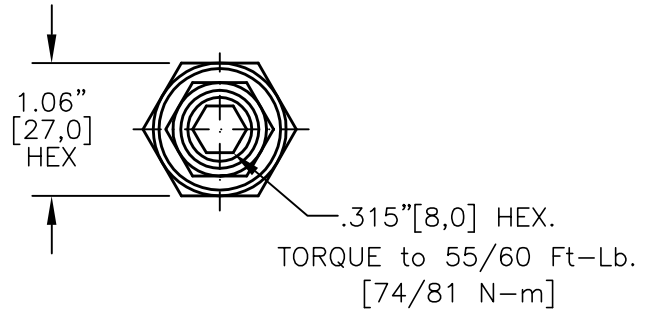
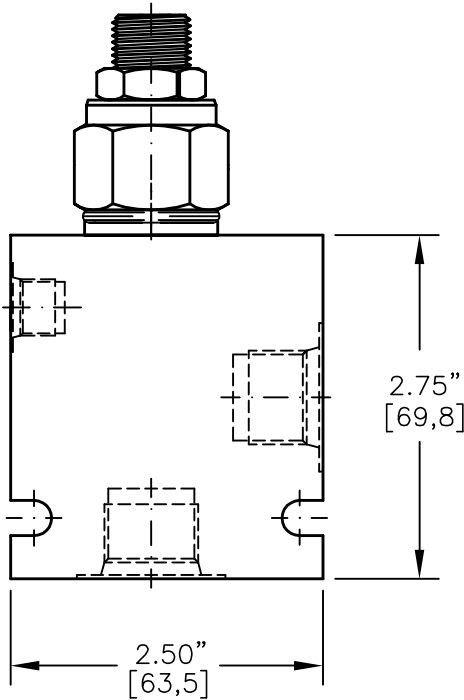
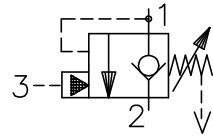

FOR ALUMINUM OR STEEL VALVE HOUSING CONFIGURATIONS SEE PAGE 0-022-1.

## CBPG-10-X-X-X-XX

- BASIC
- SIZE  
10 = 7/8"-14 UNF
- SEALS  
N = BUNA "N"  
V = VITON
- ADJUSTMENT  
S = ADJUSTING SCREW  
C = CAPPED  
T = TAMPERPROOF  
K = HANDKNOB  
M = METAL HANDKNOB

- PRESSURE RANGE  
15 = 100 TO 1500 PSI  
30 = 300 TO 3000 PSI  
50 = 500 TO 5000 PSI
- PORTS  
0 = CARTRIDGE ONLY  
03BX = G 3/8" BSPP  
04BX = G 1/2" BSPP  
08TX = SAE - #8  
10TX = SAE - #10
- "A" - ALUM. HOUSING  
"S" - STEEL HOUSING

FOR ADJUSTMENT CONTROL  
OPTIONS SEE PAGE 0-050.0

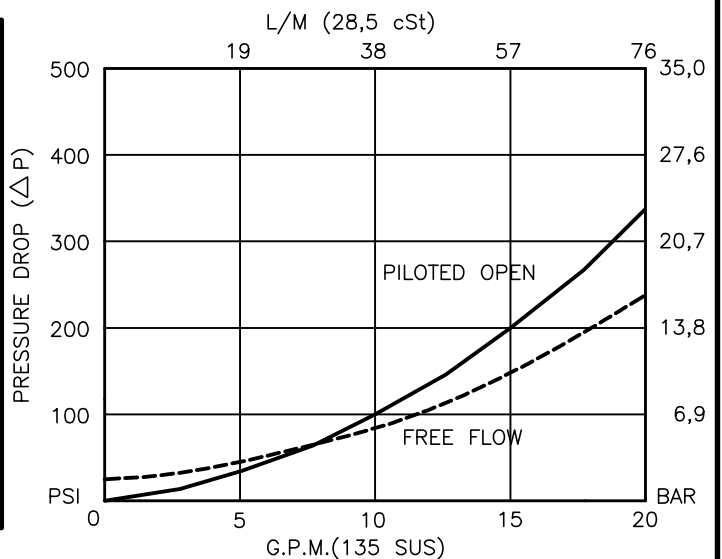



## COUNTERBALANCE VALVE POPPET TYPE, WITH FREE REVERSE FLOW & VENTED PISTON.

### DESCRIPTION

This unit is a DIRECT ACTING, SCREW IN CARTRIDGE STYLE, POPPET TYPE, ADJUSTABLE, PILOT ASSISTED, HYDRAULIC COUNTERBALANCE VALVE.

### OPERATIONS

This valve controls moving load and preventing it from running ahead of the pump, locking the load in any position, it also provides static overload and thermal expansion protection.

This valve is a MODULATING DEVICE that allows free flow from port 2 to port 1 and then blocks reverse flow until a pilot pressure INVERSELY PROPORTIONAL to the load pressure is sensed at port 3 modulating flow from port 1 to port 2.

### FEATURES AND BENEFITS

Leakproof screw adjustment.

Adjustment screw can not be backed out of the valve.

Overset protection – spring can not go solid.

Hardened precision fitted poppet & cage provides reliable, long life.

A unibody adapter cage construction provides very reliable operation.

Vented pilot piston spring chamber to atmosphere allows this valve to be used with a closed center valve or re-generative circuit.

All external carbon steel parts are plated for longer life against the elements.

Valve is available with screw, tamperproof, capped and handknob adjustments.

All cartridge valves are 100% functionally tested.

Industry common cavity.

### SPECIFICATIONS

OPERATING PRESSURE: 5,000 PSI [350 Bar]

PROOF PRESSURE: 10,000 PSI [700 Bar]

FLOW: 20.0 GPM [76 L/M] nominal. See performance chart.

PILOT RATIO: 4 to 1

INTERNAL LEAKAGE: 5 drops/min @ 90% of crack pressure.

DEFINITION OF CRACK: evident at 0.06 GPM [0.25 LPM]

VALVE HOUSINGS: 2500 PSI [175 Bar] = Aluminum – Anodized.

5000 PSI [350 Bar] = Steel – Unplated.

OPERATING TEMPERATURE: -40° to +250° F. [-40° to +120° C.]

OPERATING MEDIA: All general purpose hydraulic fluids such as MIL-H-5606, SAE-#10, SAE-#20, etc.

INSTALLATION: No restriction.

FILTRATION: 25 microns or better.

SEAL KIT NUMBER: SKN-1028 for buna "N".

SKV-1028 for viton.

WEIGHT: 0.46 lb [.21 kg] cartridge only.

VALVE CAVITY: #C1025, See Page 0-022.0.